

1

2

3

4

5

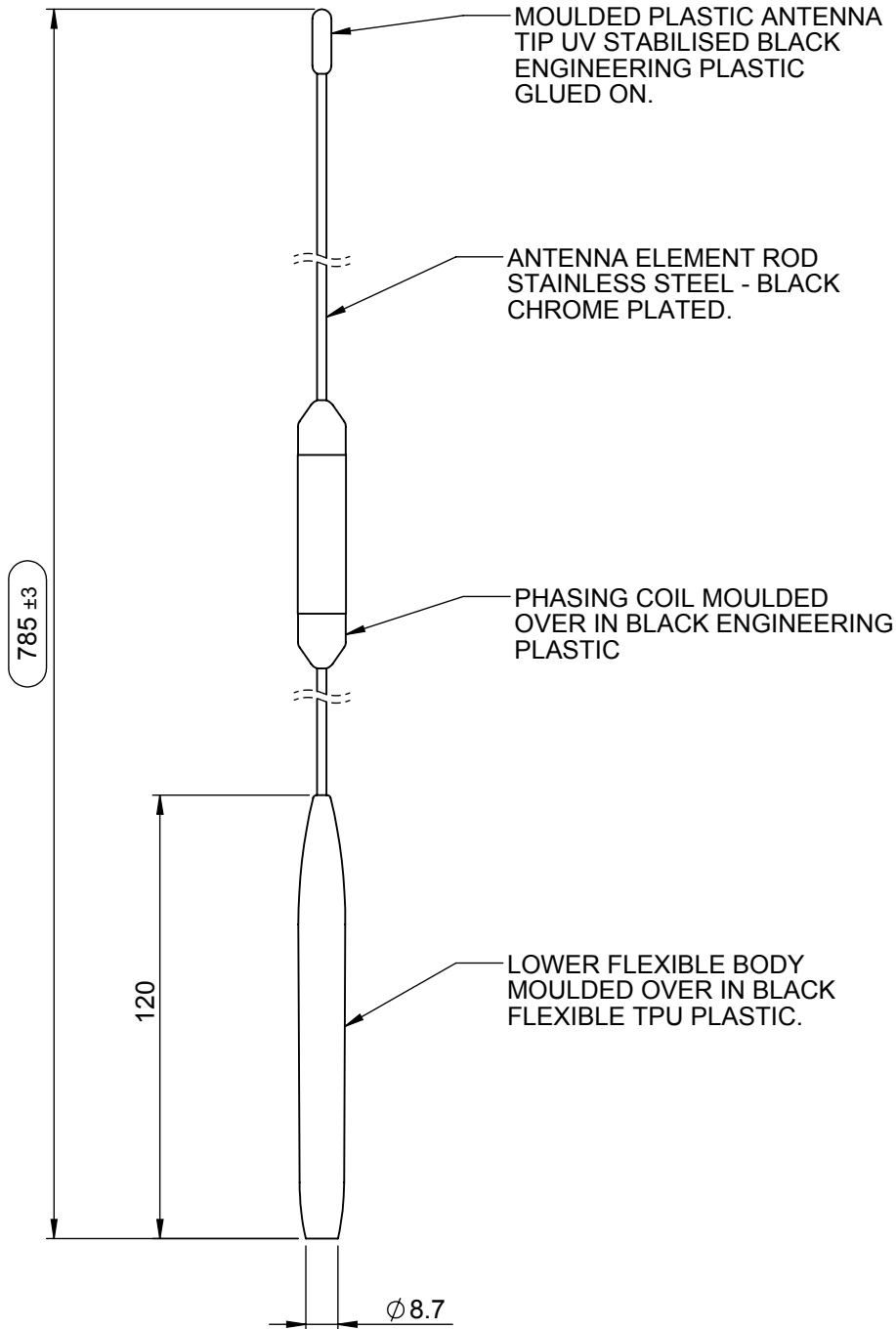

FREQUENCY:- 380 - 415 MHz
GAIN:- 7dBi

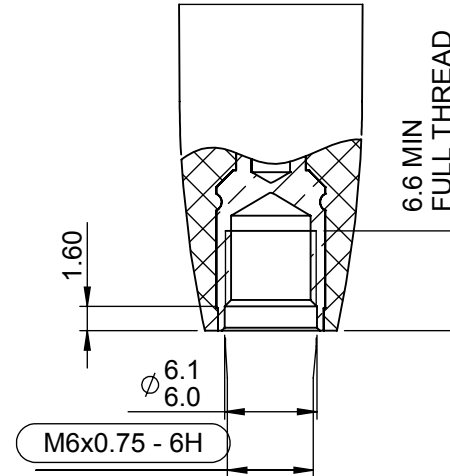

NOTES:

- SAMPLES MUST BE APPROVED BY PANORAMA ANTENNAS Q.C. BEFORE COMMENCING PRODUCTION.
- ALL PARTS MUST BE RoHS COMPLIANT AND MUST NOT CONTAIN ANY SUBSTANCES OF VERY HIGH CONCERN (SVHCs) LISTED UNDER REACH OR POLY-AROMATIC HYDROCARBONS (PAHs), OR PERSISTENT ORGANIC POLLUTANTS (POPs) CONTROLLED BY THE STOCKHOLM CONVENTION.

DRG. No. **ASF-395G7** SHEET 1 OF 1

PRODUCT/ASSEMBLY
WHIPS

DESCRIPTION
FLEXI 395MHz 7dBi ANTENNA ELEMENT

MATERIAL
N/A

FINISH
N/A

WEIGHT
70.35g

APPROVED **KD** DO.CHECK **AR**

SCALE **1:2** DIMENSIONS IN mm

DO NOT SCALE 3RD ANGLE PROJECTION

01940 C LOWER INTERNAL CONSTRUCTION MODIFIED 13/11/2013 ATB

01019 1 PRODUCTION ISSUE 24/05/2016 PE

PCN REV. DESCRIPTION DATE DRN

TOLERANCES UNLESS OTHERWISE STATED

0 DEC. PLACE ±0.5 2 DEC. PLACES ±0.1

1 DEC. PLACE ±0.2 ANGULAR ±1°

△ DENOTES LATEST ISSUE CHANGES ○ DENOTES CRITICAL VALUE

 **PANORAMA ANTENNAS**

THIS DOCUMENT MUST NOT BE COPIED OR DISCLOSED TO A THIRD PARTY WITHOUT THE WRITTEN CONSENT OF PANORAMA ANTENNAS LTD.

© 2016 **A4**