

1

2

3

4

5

A

B

C

D

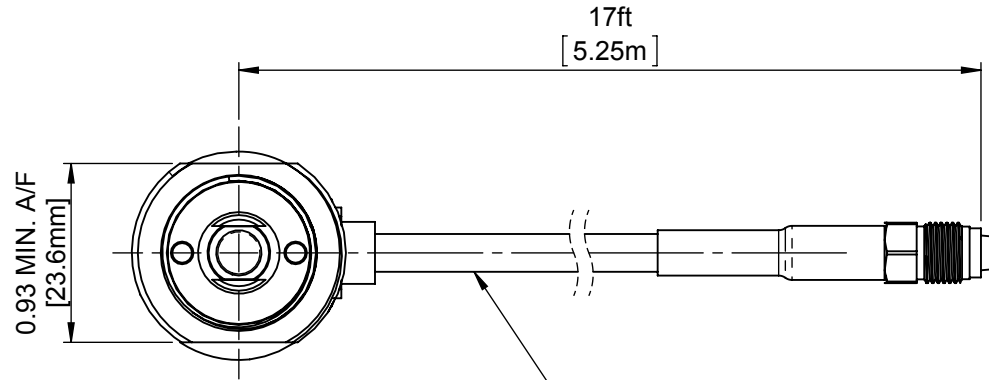

CS23 - RG58 C/U  
COAX CABLE



MOUNTING NUT  
NICKEL PLATED BRASS

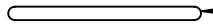

'O' RING  
NBR 70 SHORE A

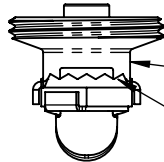

MOUNT SUB ASSEMBLY

STAINLESS STEEL EARTHING TEETH

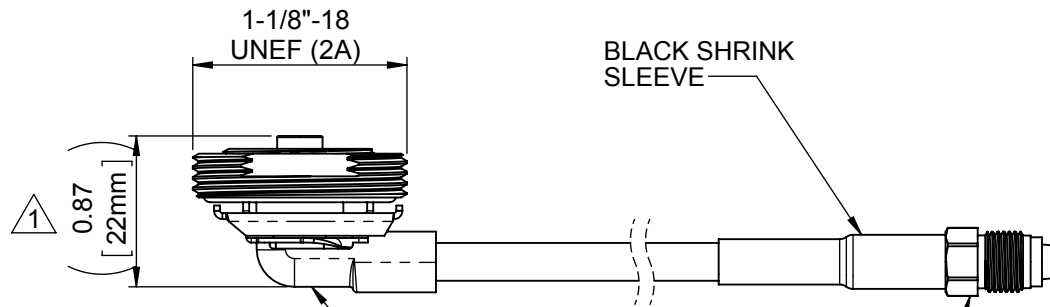

BLACK SHRINK  
SLEEVE

MOULDED BOOT  
BLACK NYLON

FME JACK  
HEX NUT

DRG. No. **MNMOM-5F**

SHEET  
1 OF 1

PRODUCT/ASSEMBLY

**MNMO MOUNT**

DESCRIPTION

**MNMO MOUNT ASSEMBLY -  
17ft (5.25m) CS23 COAX CABLE  
- FME(f) CONNECTOR**

MATERIAL

N/A

FINISH

N/A

WEIGHT

**270g**

APPROVED

**JJ**

DO.CHECK

**ATB**

SCALE

**1:1**

DIMENSIONS IN  
INCHES [mm]

DO NOT  
SCALE

3RD ANGLE  
PROJECTION

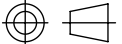

PCN

REV.

DESCRIPTION

DATE

DRN

01019

1

PRODUCTION  
ISSUE. DIMENSION.  
UPDATED.

10/09/2013

PE

TOLERANCES UNLESS OTHERWISE STATED

1 DEC. PLACE  $\pm 0.02''$  3 DEC. PLACES  $\pm 0.005''$

2 DEC. PLACE  $\pm 0.01''$  ANGULAR  $\pm 1^\circ$



DENOTES  
LATEST ISSUE  
CHANGES



DENOTES  
CRITICAL  
VALUE

**PANORAMA  
ANTENNAS**

THIS DOCUMENT MUST NOT BE COPIED  
OR DISCLOSED TO A THIRD PARTY  
WITHOUT THE WRITTEN CONSENT OF  
PANORAMA ANTENNAS LTD.

© **2012**

**A4**