

3RD ANGLE PROJECTION
DO NOT SCALE

DENOTES LATEST ISSUE CHANGES

DENOTES CRITICAL VALUE

TOLERANCES UNLESS OTHERWISE STATED
 0 DEC. PLACE ±0.5 2 DEC. PLACES ±0.1
 1 DEC. PLACE ±0.2 ANGULAR ±1°

© 2016 A3 THIS DOCUMENT MUST NOT BE COPIED OR DISCLOSED TO A THIRD PARTY WITHOUT THE WRITTEN CONSENT OF PANORAMA ANTENNAS LTD.

DWG. No. **CMWB2-038-6-NJ**

FREQUENCIES:
380 MHz TO 6GHz

A
B
C
D
E
F

A
B
C
D
E
F

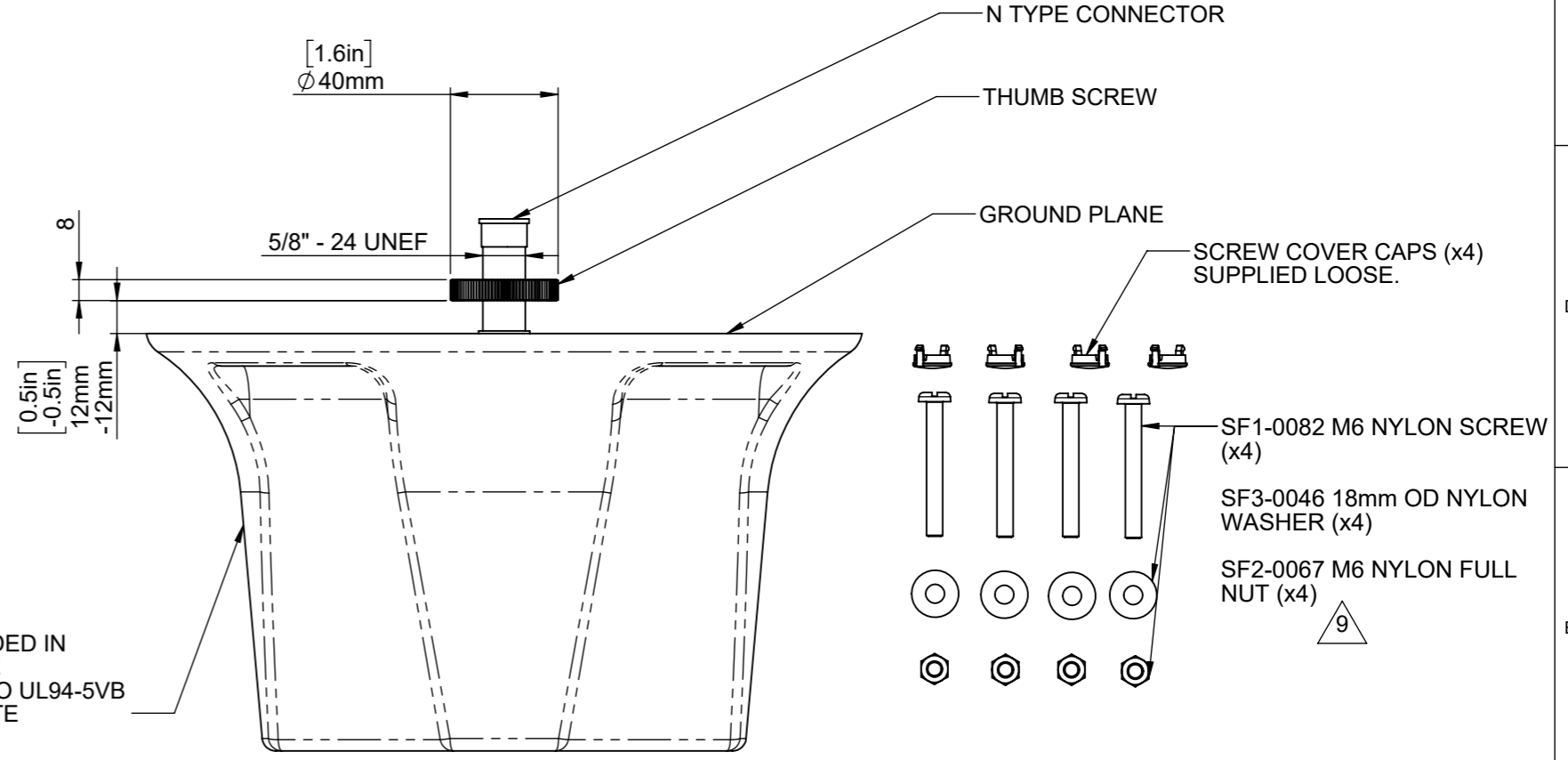
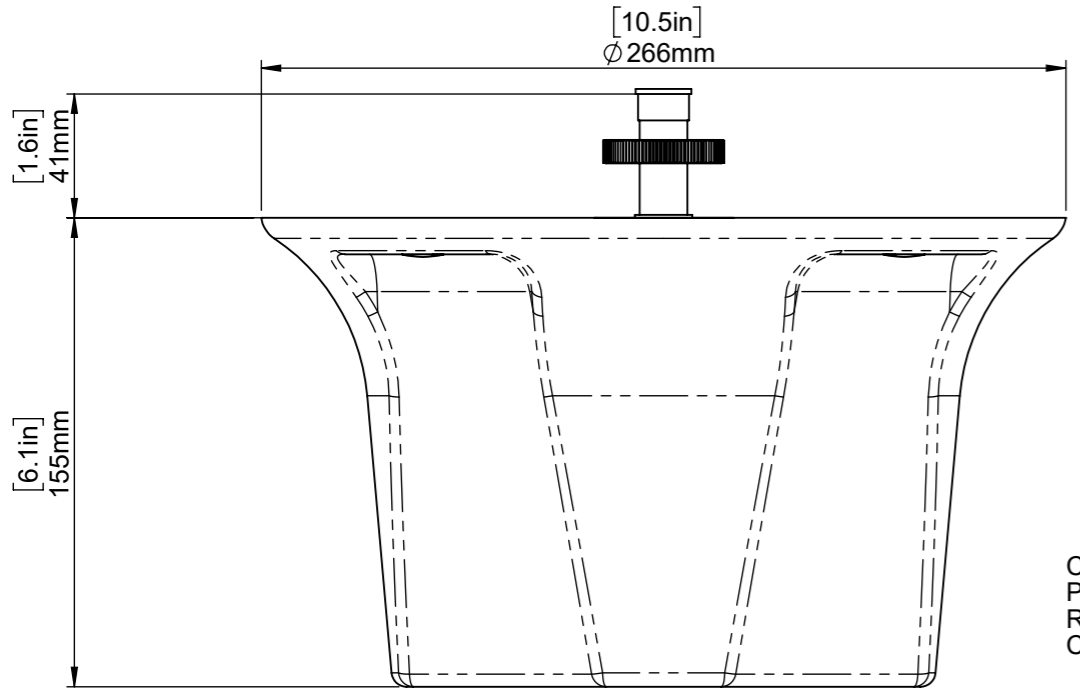
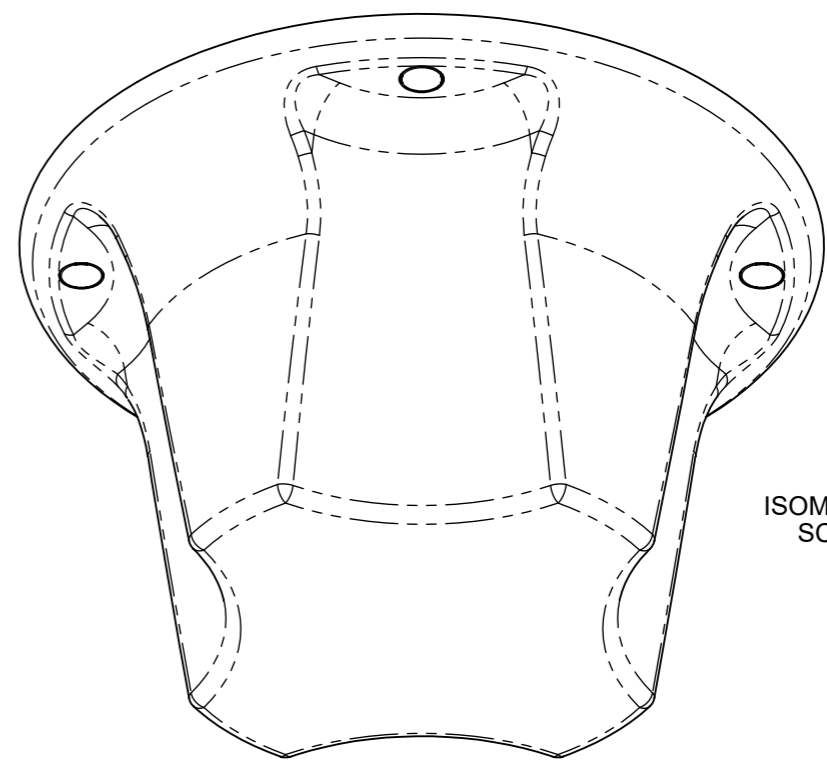
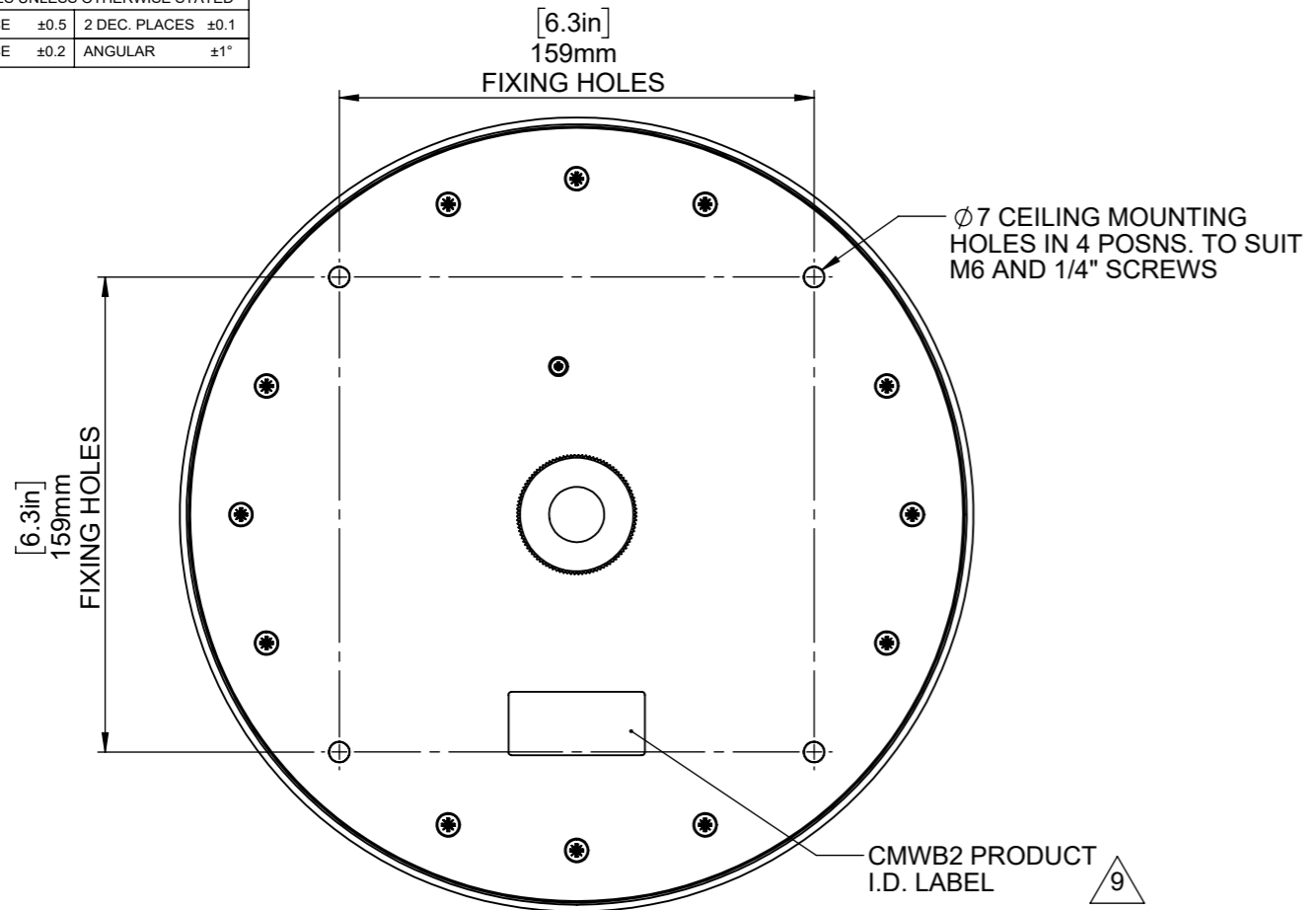

- NOTES:
- SAMPLES MUST BE APPROVED BY PANORAMA ANTENNAS Q.C. BEFORE COMMENCING PRODUCTION.
 - ALL MATERIALS SUPPLIED MUST BE RoHS2 (DIRECTIVE 2011/65/EU) COMPLIANT AND MUST NOT CONTAIN ANY SUBSTANCES OF VERY HIGH CONCERN (SVHCs) LISTED UNDER REACH OR POLY-AROMATIC HYDROCARBONS (PAHs), OR PERSISTENT ORGANIC POLLUTANTS (POPs) CONTROLLED BY THE STOCKHOLM CONVENTION.

PCN	REV.	DESCRIPTION	DATE	DRN.
01019	7	CONNECTOR END CAP ADDED	08/07/2015	AR
01019	8	INTERNALS AND NOTES UPDATED.	22/07/2016	AR
01019	9	LABEL AND FASTENERS ADDED	08/02/2017	IC

PRODUCT/ASSEMBLY	SPECIAL PRODUCTS
MATERIAL	SEE PART DRAWINGS
FINISH	SEE PART DRAWINGS

DESCRIPTION					CMWB2-038-60 ASSEMBLY DRAWING
APPROVED	KD	D.O. CHECK	PE	SCALE	1:2.5
				DIMENSIONS	IN mm