

1

2

3

4

5

A

B

C

D

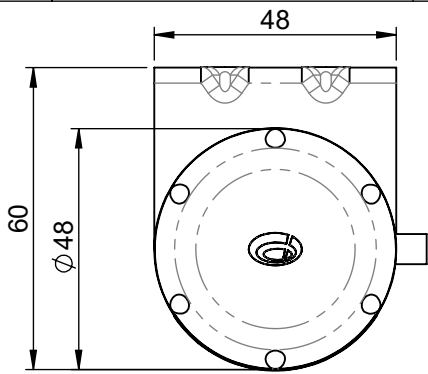

FREQUENCIES:
2.4GHz
4.9-6.0GHz



4 No.8 RAWL PLUGS
- SUPPLIED LOOSE

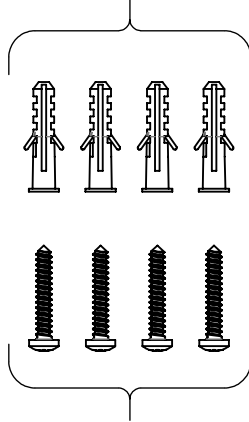

4 No. 8x25 LONG
PAN HEAD POZI-DR.
STAINLESS STL. SCREWS
- SUPPLIED LOOSE

COVER MOULDED
IN WHITE PCASA

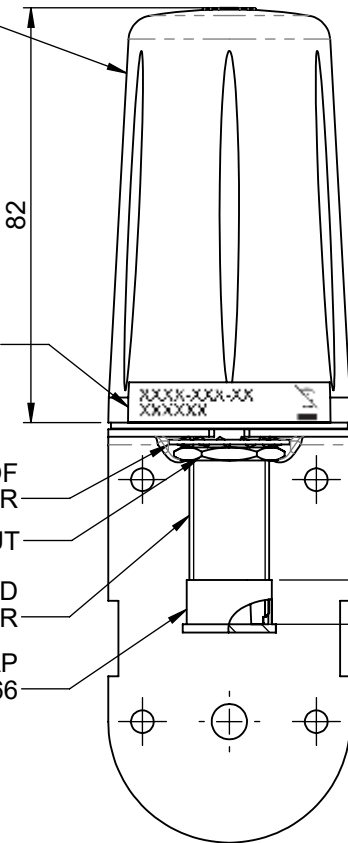

1.2 ADHESIVE PAD

PRODUCT LABEL

XXXX-XXX-XX
XXXXXX

SHAKE PROOF
WASHER

NUT

N FERRULE BULK-HEAD
CONNECTOR

PROTECTIVE CAP
SP8-0666

25 MAX. PANEL
THICKNESS

39

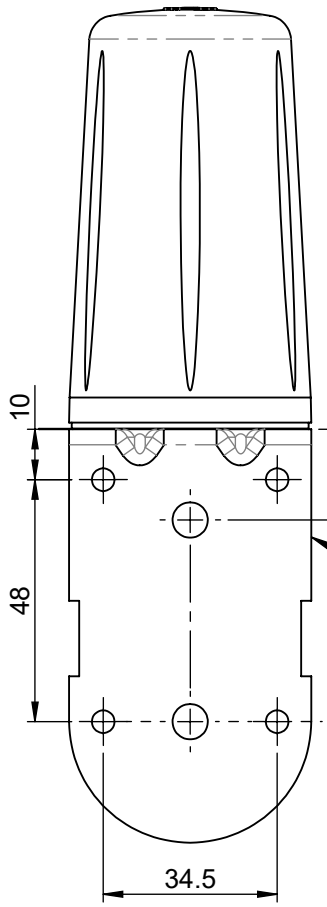

METAL ANGLE BRACKET
-ZINC PLATED

ISO VIEW
SCALE 1:2

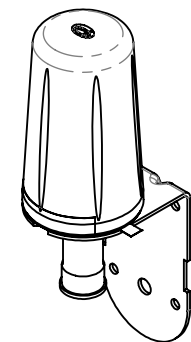

NOTES:

- SAMPLES MUST BE APPROVED BY PANORAMA ANTENNAS Q.C. BEFORE COMMENCING PRODUCTION.
- ALL MATERIALS SUPPLIED MUST BE RoHS2 (DIRECTIVE 2011/65/EU) COMPLIANT AND MUST NOT CONTAIN ANY SUBSTANCES OF VERY HIGH CONCERN (SVHCs) LISTED UNDER REACH OR POLY-AROMATIC HYDROCARBONS (PAHs), OR PERSISTENT ORGANIC POLLUTANTS (POPs) CONTROLLED BY THE STOCKHOLM CONVENTION.

DRG. No. **LPB-24-58-NJ** SHEET 1 OF 1

PRODUCT/ASSEMBLY
LOW PROFILE

DESCRIPTION
**LOW PROFILE ANTENNA
2.4GHz & 4.9-6.0GHz N
SOCKET**

MATERIAL
N/A

FINISH
N/A

WEIGHT
231.17g

APPROVED **JJ** DO.CHECK **MM**

SCALE 1:1.5 DIMENSIONS IN mm

DO NOT SCALE 3RD ANGLE PROJECTION

01019	A	INITIAL ISSUE	17/08/2016	AR
-------	---	---------------	------------	----

01019	1	PRODUCTION ISSUE	01/09/2016	AR
-------	---	------------------	------------	----

01019	2	PRODUCTION DRAWING AND COVER MATERIAL UPDATED	26/10/2016	KW
-------	---	---	------------	----

01019	3	BRACKET, FASTENERS AND LABEL ADDED	13/06/2017	PE
-------	---	------------------------------------	------------	----

PCN	REV.	DESCRIPTION	DATE	DRN
01019	A	INITIAL ISSUE	17/08/2016	AR
01019	1	PRODUCTION ISSUE	01/09/2016	AR
01019	2	PRODUCTION DRAWING AND COVER MATERIAL UPDATED	26/10/2016	KW
01019	3	BRACKET, FASTENERS AND LABEL ADDED	13/06/2017	PE

TOLERANCES UNLESS OTHERWISE STATED

0 DEC. PLACE ±0.5 2 DEC. PLACES ±0.1

1 DEC. PLACE ±0.2 ANGULAR ±1°

△ DENOTES LATEST ISSUE CHANGES ○ DENOTES CRITICAL VALUE



THIS DOCUMENT MUST NOT BE COPIED OR DISCLOSED TO A THIRD PARTY WITHOUT THE WRITTEN CONSENT OF PANORAMA ANTENNAS LTD.