

3RD ANGLE PROJECTION		DO NOT SCALE	
DENOTES LATEST ISSUE CHANGES		DENOTES CRITICAL VALUE	
TOLERANCES UNLESS OTHERWISE STATED			
0 DEC. PLACE	±0.5	2 DEC. PLACES	±0.1
1 DEC. PLACE	±0.2	ANGULAR	±1°

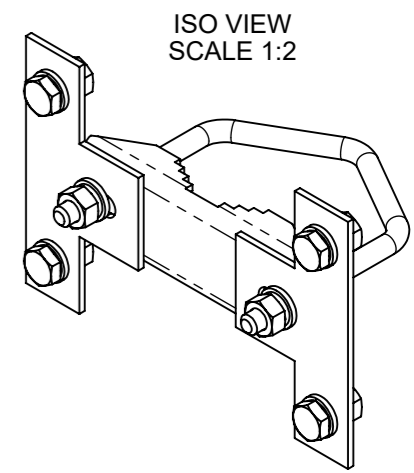
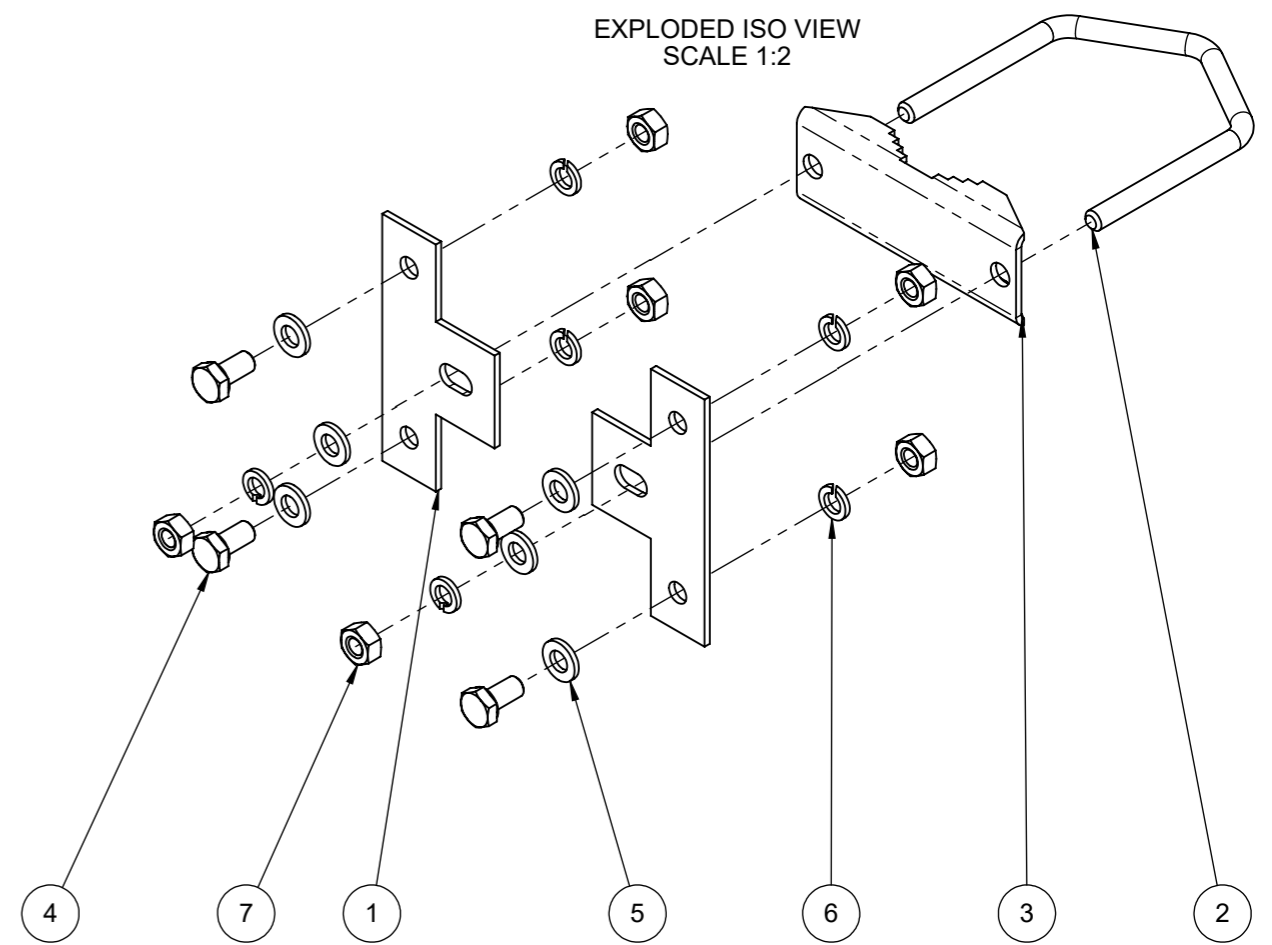
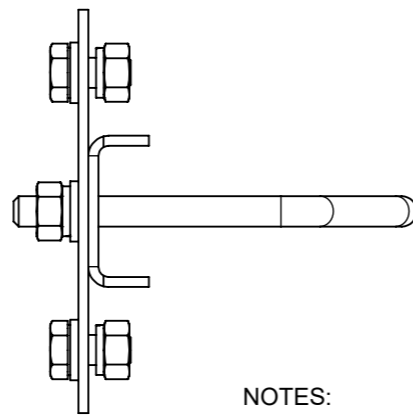
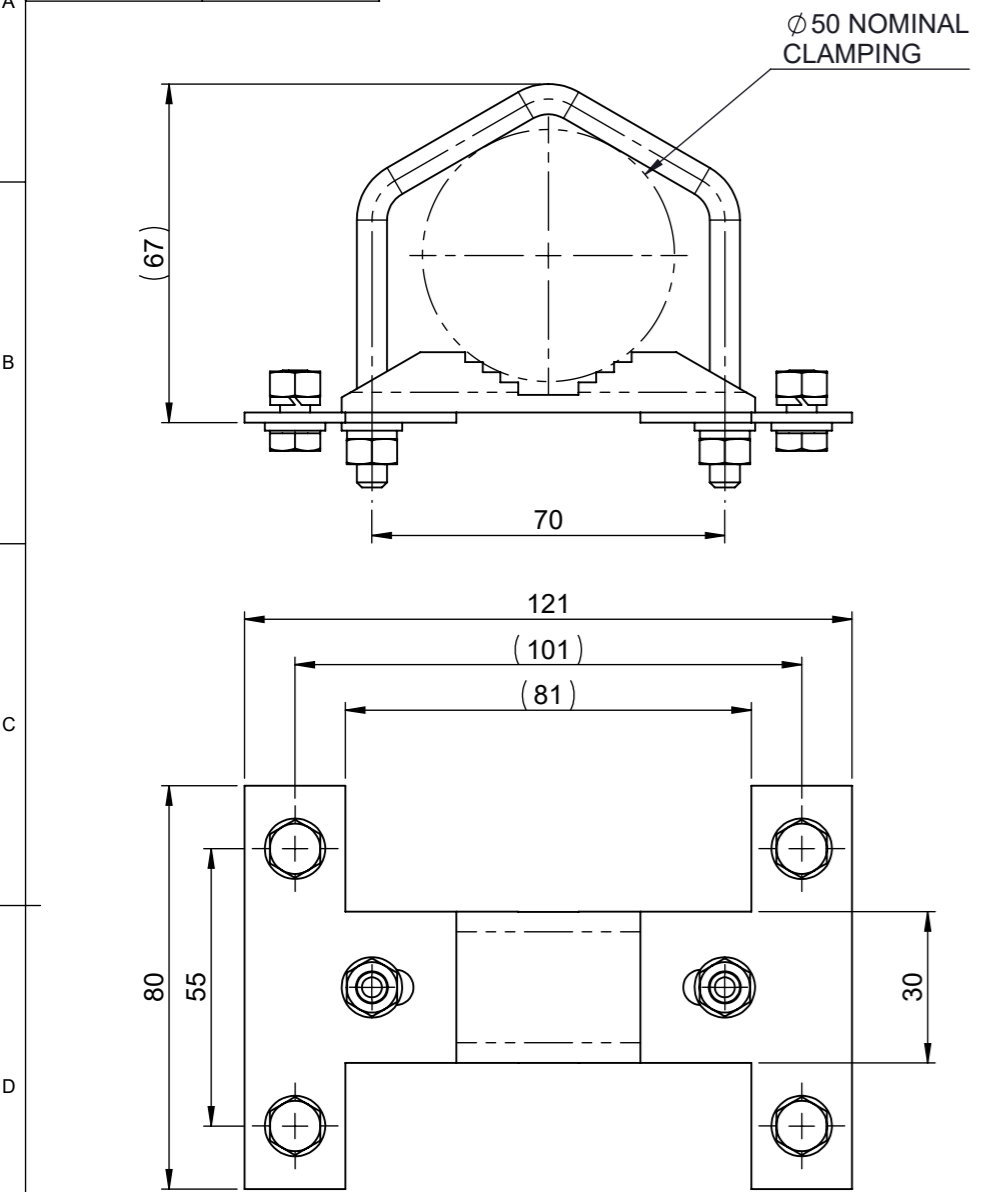

NOTES:

- ALL COMPONENTS TO BE SUPPLIED LOOSE AND PACKED IN CLEAR POLYBAG.
- MATERIALS: ALL COMPONENTS TO BE A2 OR AISI 304 STAINLESS STEEL. ALTERNATIVES ARE NOT PERMITTED.
- THIS IS AN ELECTRICAL COMPONENT AND MUST BE SUPPLIED CLEAN AND FREE FROM OIL AND GREASE.
- REFER TO 3D FILE FOR OTHER DIMENSIONS.
- ALL MATERIALS SUPPLIED MUST BE RoHS2 (DIRECTIVE 2011/65/EU) COMPLIANT AND MUST NOT CONTAIN ANY SUBSTANCES OF VERY HIGH CONCERN (SVHCs) LISTED UNDER REACH OR POLY-AROMATIC HYDROCARBONS (PAHs), OR PERSISTENT ORGANIC POLLUTANTS (POPs) CONTROLLED BY THE STOCKHOLM CONVENTION.
- SAMPLES MUST BE APPROVED BY PANORAMA ANTENNAS Q.C. BEFORE COMMENCING PRODUCTION.

ITEM NO.	PART NUMBER	DESCRIPTION	QTY.
1	SP5-0582	B6SE MAST ADAPTER T PLATE	2
2	SP4-0013	"V" BOLT - M6. STAINLESS STEEL.	1
3	SP5-0300	WM11 BRACKET - STAINLESS STEEL.	1
4	SF1-0385	M6 x 12mm LONG HEX SCREW- A2 STAINLESS STEEL	4
5	SF3-0010	M6 STAINLESS STEEL PLAIN WASHER	6
6	SF3-0011	M6 STAINLESS STEEL SINGLE COIL SPRING WASHER	6
7	SF2-0012	M6 FULL NUT- STAINLESS STEEL.	6

PRODUCT/ASSEMBLY 2020 - SUB-ASSEMBLIES				DESCRIPTION B6SE U-BOLT MAST BRACKET			
MATERIAL SEE NOTES				APPROVED JJ D.O. CHECK MM SCALE 1:1.5 DIMENSIONS IN mm			
FINISH SEE INDIVIDUAL PART DRAWINGS							
01019	1	PRODUCTION ISSUE	12/06/2018				
PCN	REV.	DESCRIPTION	DATE	DRN.			